

SCHEMA FUNZIONALE IMPIANTO BASSINA COMPACT-ON / OC Equipment working diagram

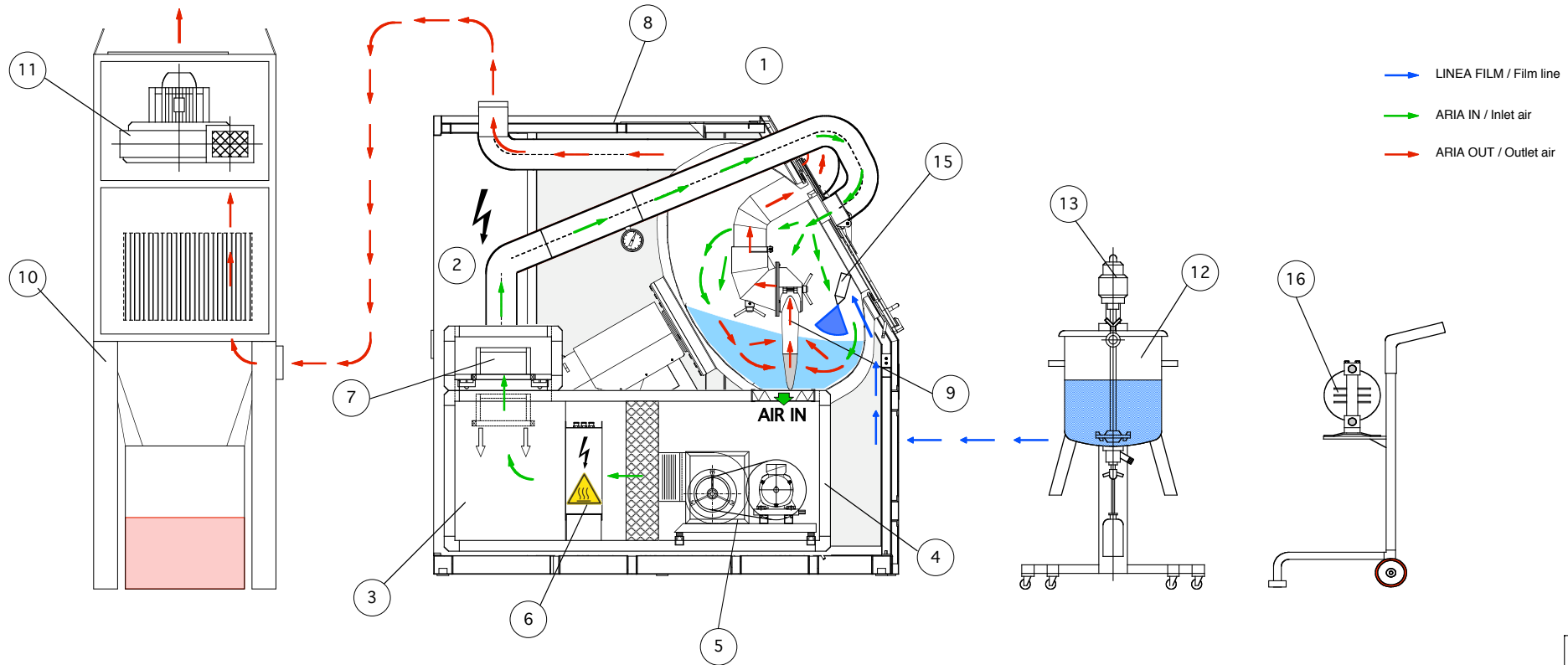

- LINEA FILM / Film line
- ARIA IN / Inlet air
- ARIA OUT / Outlet air

DETTAGLIO PARETE FRONTALE / Front wall detail

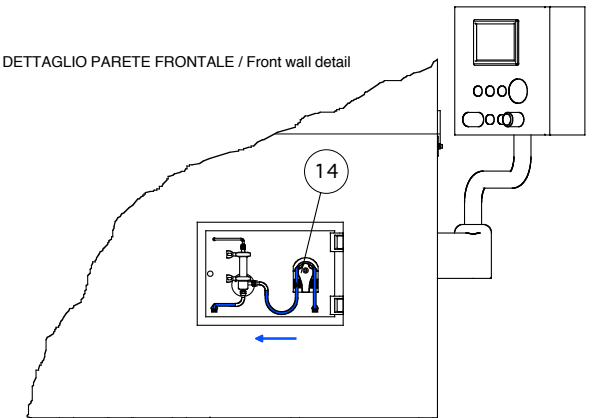

RIF / Ref	DESCRIZIONE / Description
1	BASSINA / Coating pan
2	QUADRO ELETTROPNEUMATICO / Electro-pneumatic cabinet
3	GRUPPO ARIA TRATTATA DI ESSICCAMENTO / Air handling unit
4	PREFILTRO / Pre-filter
5	VENTILATORE DI MANDATA / Inlet air fan
6	RESISTENZE ELETTRICHE / Electrical resistances
7	FILTRO / Filter
8	MISURAZIONE PORTATA ARIA IN / Inlet air meter
9	VOMERE ASPIRANTE / Air exhausting paddle
10	FILTRO ABBATTIMENTO POLVERI / Dust collector unit
11	VENTILATORE DI ASPIRAZIONE / Air exhausting fan
12	CONTENITORE CARRELLATO / Wheeled tank
13	AGITATORE PNEUMATICO / Pneumatic mixer
14	POMPA PERISTALTICA / Peristaltic pump
15	PISTOLA FILMATURA / Film coating spray gun
16	POMPA DI LAVAGGIO / Washing pump (OPTIONAL)
17	UNITA' MOTOCONDENSANTE / Condensing unit (OPTIONAL)

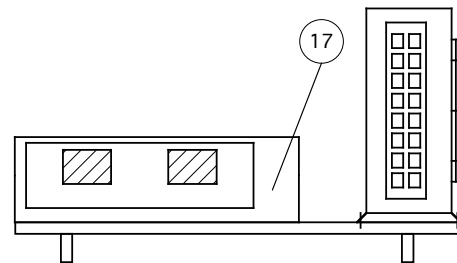

OGS
G.S. DIVISIONE VERNICIATURA SRL

SF-0003-1